



Transmission solutions for heavy industry

- Maintenance
- Replacement
- Engineering
- Applications



## MGH Diensten: AIQ Retrofit Quick Guide



### AIQ Core Quick Starting Guide

#### Scope of delivery

- AIQ Core Logic Module
- AIQ Core Retrofit Kit Sensor Interface
- 3x mounting screw (M6x14)
- 1x O-ring for sealing the device
- 3x housing screw (2.5 x 10mm)
- 1x sticker
- 1x mounting adapter AIQ Core
- 1x mounting Kit Temperature Sensor
- 1x mounting kit speed sensor
- 1x mounting tool Torx T8



If the sensor is ordered together with a **FLENDER gear unit**, the sensor is already mounted on the gear unit.

#### General Information

**IMPORTANT:** Please refer to the documentation supplied with the device before connecting and commissioning the device. You can find the complete documentation for the device on the Internet at: [www.Flender.com](http://www.Flender.com)



The symbols refer to detailed information in the user manual.

#### Safety Notifications

The device AIQ Core is not subject to the EC Machinery Directive 2006/42/EC.  
 The AIQ Core device must not be used for safety-relevant tasks and critical switching operations.  
 The device may only be used within the restrictions of use specified in the technical data.  
 AIQ Core equipment may only be installed, operated, and maintained by qualified personnel who have been trained in accordance with the applicable regulations.

The device is configured for a specific gearbox for monitoring machine-related vibrations. Do not use this device on another gearbox.

### 1

#### Display & Control Elements

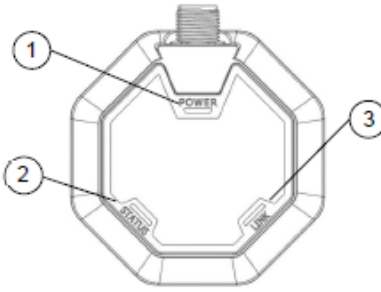

- LED: Power supply**  
 1Hz flash: Boot  
 5Hz flash: Sensor Error  
 Permanent light: Device ready for operation
- LED: Status**  
 1 Hz flash: Action/Service at gear unit needed  
 2Hz flash: Alarm  
 Permanent light: Gear Unit is ok
- LED: Link**  
 lights up when the network connection is active  
 1 Hz flash: Bluetooth connection is active

When Bluetooth teach-in mode is activated, the LEDs flash clockwise one after the other.



Read the user manual for more details on display and controls or use the HELP section of the AIQ App



## Transmission solutions for heavy industry

- Maintenance
- Replacement
- Engineering
- Applications

# MGH

MAINTENANCE & GEARS

## 2 Installation AIQ Core



Before using the equipment for the first time, ensure that the equipment is not damaged before installation. If in doubt, you should contact a qualified electrician or your customer support representative (see Contacts).

### 2.1 Device Mounting



If the sensor is ordered together with a FLENDER gearbox, the sensor is already mounted on the gearbox. In this case, proceed to point 2.2.

When ordering the sensor for an operating gearbox, a drawing is enclosed with the device showing the best mounting position.

1. Prepare the mounting surface for installation of the device. The device should ideally be mounted above the input shaft on the gearbox housing. A system structure that is as rigid as possible should be ensured. The ideal positioning can be viewed in the enclosed sheet "Positioning".

Note: Mounting on covers is not recommended and leads to incorrect measurement results in vibration measurement.

2. Prepare threaded hole according to sketch. A reduction  $> \varnothing 25\text{mm}$  is recommended to compensate for unevenness on the gearbox surface.

Note: Alternatively, the mounting adapter can be glued using an adhesive suitable for vibration measurements (e.g., Loctite 330).

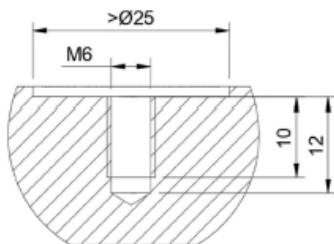

3. Clean the attachment surface and protect it from corrosion with suitable aids.

4. Attach the mounting adapter with cylinder head bolt (M6x14), paying attention to the orientation.

Note: The final cable routing is specified hereby

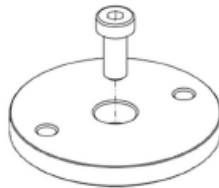

5. Attach sensor interface to mounting adapter (M6x14).

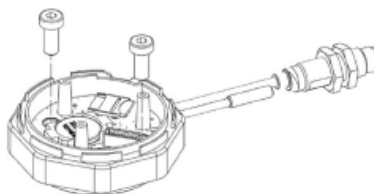

6. Insert O-Ring (Ø0x2mm) Pos. 1 into the sealing groove.

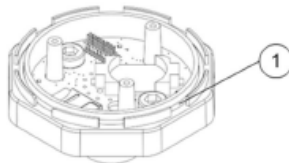

7. Put on AIQ Core logic module and screw in housing screws with a torque of 0.8Nm. (Torx Plus 8).

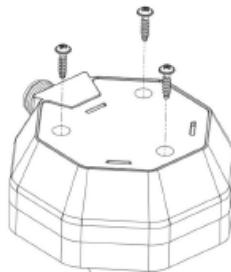

8. The temperature sensor is fed into the oil chamber below the vent screw via the adapter. To do this, remove the breather on the gearbox (Pos. 1). Subsequently, the adapter (Pos. 2) is screwed into the same place and the temperature sensor of the AIQ Core is inserted into the tube via the Skintop screw connection (Pos. 3).

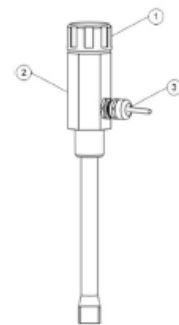

9. Mount the speed sensor with the gearbox-specific mounting kit onto the input shaft of the gearbox and fix the cable routing according to the specifications of the mounting kit. The speed sensor must be set to a sensing distance of 5 mm.

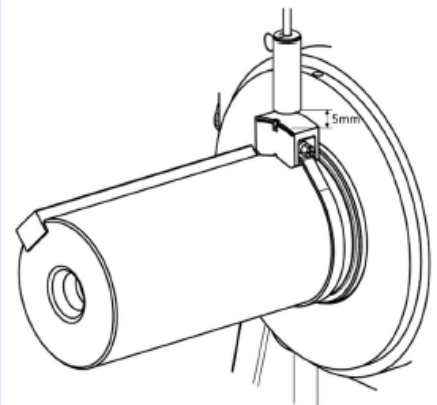

Use only suitable mounting material from the mounting kit! Material must be temperature and oil resistant.



10. Clean the top side of the device and seal it with the supplied sticker, observing the orientation.

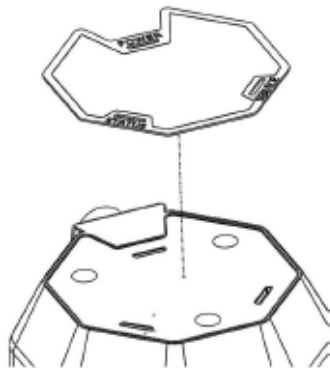

## 2.2 Device connection (Cable)

The electrical connection of the device is described below.



When working on electrical equipment, observe the 5 safety rules of electrical engineering. Always make sure that you are working in a de-energized state.

1. Take the supplied connection cable and connect it to the M12 plug connection of the device.
2. Connect the cables to the system control system according to the following connection overview.

Pin Assignment	Nr.	Signal	Color
<p>Front view of the device</p>	1	Analog Output 1	white
	2	+24VDC	brown
	3	Analog Output 2	green
	4	Digital Output 1	yellow
	5	RPM Output	grey
	6	Digital Output 2	pink
	7	GND	blue
	8	Digital Input 1	red



Connect the device to the power supply according to the specifications (18-32 VDC).

As soon as the device is turned on, the power LED flashes green. In this start-up phase, the device must not be disconnected from the power supply.



Warning: Risk of damage to the device by connection to an unsuitable power supply! Only a power supply which complies with the specifications in the technical data of the equipment, and which complies with the relevant legal requirements for such components may be used.

Once the start-up phase of the device is over, the status LED indicates the current alarm status:

- Green: Device is ready

Ensure that the machine is in its normal operating condition (i.e., operating parameters such as temperature or oil pressure should be within the intended normal range).

### 2.2.1 Digital / Analog Outputs

The device provides three digital (DO1, DO2, RPM) and two analog output signals (AO1, AO2), which can be connected to a customer controller. This makes it possible to transmit signals such as *transmission status* to the customer control. The default configuration can be found in the table below and adjusted via the AIQ App:

DO1, DO2:	24V DC / 200mA
RPM Output:	24V, 20mA (High Speed Output)
AO1, AO2:	0-20mA

Pin Assignment	Nr.	Signal	Color
<p>Front view of the device</p>	1	AO1 (Temp. 0...20mA)	white
	2	+24VDC	brown
	3	AO2 (vRMS 4...20mA)	green
	4	DO1 (Status)	yellow
	5	RPM Output	grey
	6	DO2 (Oil Temp. Status)	pink
	7	GND	blue
	8	Digital Input	red



## Transmission solutions for heavy industry

- Maintenance
- Replacement
- Engineering
- Applications



### 2.3 Device Teaching

The device monitors changes in the vibration behavior of the gearbox. Therefore, an initial measurement is carried out initially.

This measurement starts automatically after approx. 100 operating hours.



The learning mode should only be switched on after the plant has been commissioned. Make sure the machine is in its normal operating condition (i.e., operating parameters such as temperature or oil pressure should be within the intended normal range) before switching to learn mode.

### 2.4 Warning and Notification

If elevated readings are recorded, the device generates a warning. By default, the sensor displays a warning status on the status LED.

In addition to the LED, the status can also be transmitted to a higher-level PLC via a digital output (DO1 / DO2) (see 2.2.1). The alert can be assigned to the corresponding output via the app (see 2.5).

### 2.5 Connection

In addition to wired integration into a PLC, the AIQ Core also offers the possibility of wireless communication via Bluetooth and Wi-Fi.

#### 2.5.1 Pairing Mode / Bluetooth

To connect the AIQ Core to the smartphone, start the pairing mode, there are two possibilities:

1. If the device is powered, the pairing mode is activated for 3 minutes. If this time has elapsed, a new pairing mode can be activated by disconnecting and reconnecting the power supply.

2. If the pairing mode is to be achieved without reboot, the digital input (DI1) can be supplied with 24V for 2 seconds. This will activate the pairing mode for 3 minutes.

#### 2.5.2 Wi-Fi



Connecting the device to a network has the advantage of being able to reach the system online. Users do not need to be connected locally to the sensor via Bluetooth

If the device is connected to a Wi-Fi access point, it is possible to access the contents of the device online. When the synchronization function is released, measured values can be uploaded to the AIQ cloud portal and further functions can be activated there.

To install a Wi-Fi connection, follow the installation instructions of the Wi-Fi access point.



The Wi-Fi access point is not part of the delivery. It must be purchased separately.

To connect the device to an existing Wi-Fi infrastructure, it is necessary to store the connection settings of the Wi-Fi network in the device. This can be done via the AIQ App (see 2.7).

#### 2.6 Factory - Reset

If the device is to be reset to its factory settings, the digital input (DI1) can be supplied with 24V for 15 seconds. This activates the "Factory Reset" function in the AIQ App.

If the device is reset to its factory settings, all settings made by the customer will be lost.

### 2.7 AIQ App

The AIQ App supports you in using the device.

In the event of an alarm on the AIQ Core, the AIQ App provides detailed information.

If sensor signals are transmitted to a customer's controller, the AIQ App makes it possible to set them customer-specifically.

To use the AIQ App, download the app from your app Store (iOS) or Play Store (Android) and follow the instructions. The following QR code will take you directly to the app.

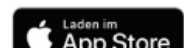

### 3 Service & Support

The contents of this publication have been carefully checked for consistency with hardware and software. Since deviations cannot be completely excluded, we cannot guarantee complete consistency. The information in this publication is checked regularly, necessary corrections are included in the following editions.

www.flender.de  
At Industriepark 2  
D-46582 Voerde, Germany

E-Mail: [aiq-support@flender.com](mailto:aiq-support@flender.com)

Further information on service and support can be found on the Internet: [www.flender.com](http://www.flender.com)

